



**GREELEY AND HANSEN**

# **Optimizing Anaerobic Digestion Improvements**

**Becky Schaefer – Greeley and Hansen**

**Nancy Clay – City of South Bend**

**November 18, 2010**

# Agenda

---

- **Digester Improvement Goals**
- **Background**
- **Optimization Evaluation**
  - Volatile solids loading
  - Solids retention time
  - Net energy
- **Conclusion**

# Digester Improvement Goals

---

- **Reliable operation**
- **Increase energy production**
- **Class A sludge?**
- **Cost effective improvements**
  - **Maximize the use of existing facilities**

# Background

## South Bend's Digesters Anaerobic Mesophilic

### GAS STORAGE SPHERES

- Out of service

### SLUDGE STORAGE TANKS (2 & 4)

- Not heated
- Not mixed
- Floating cover (no gas recovery)

### FLARE

Class B Sludge

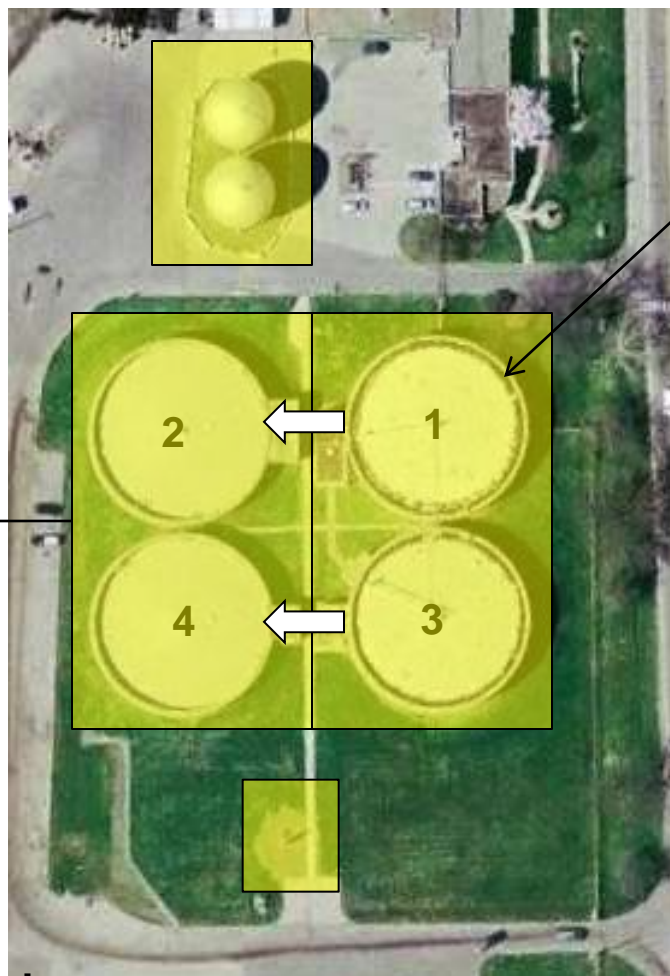

Google Earth Image

110'  
Dia.  
2 MG  
(typ)

### PRIMARY DIGESTERS 1 & 3

- Heated with digester gas supplemented by natural gas
- Recirculation Mixing
- Floating covers with minimal gas storage capabilities

# Background

## Process Evaluation

---

**Could South Bend's digester system be optimized by converting to a Temperature Phased Anaerobic Digestion (TPAD) process?**

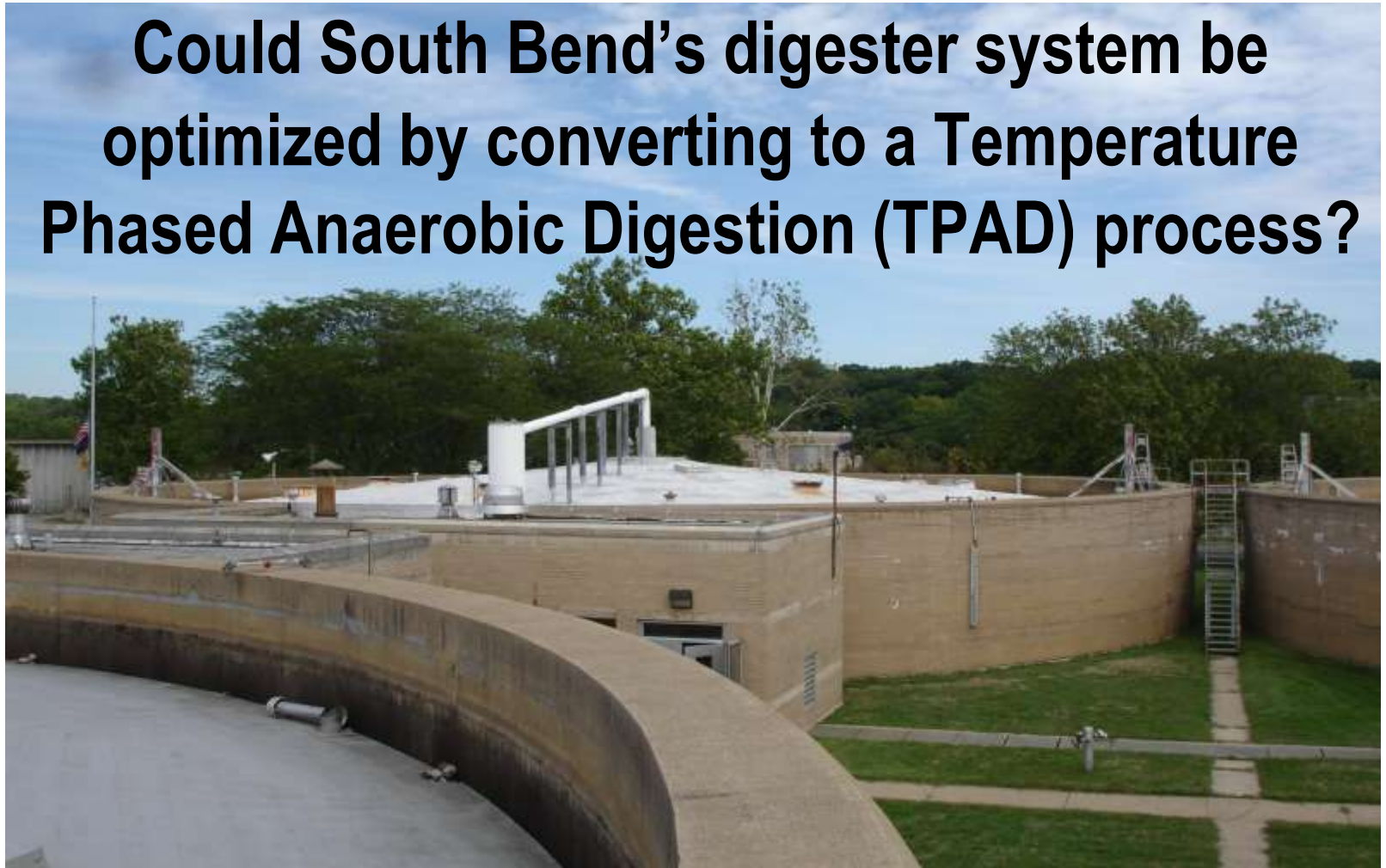

# Background

## Why Temperature Phased Anaerobic Digestion (TPAD)?

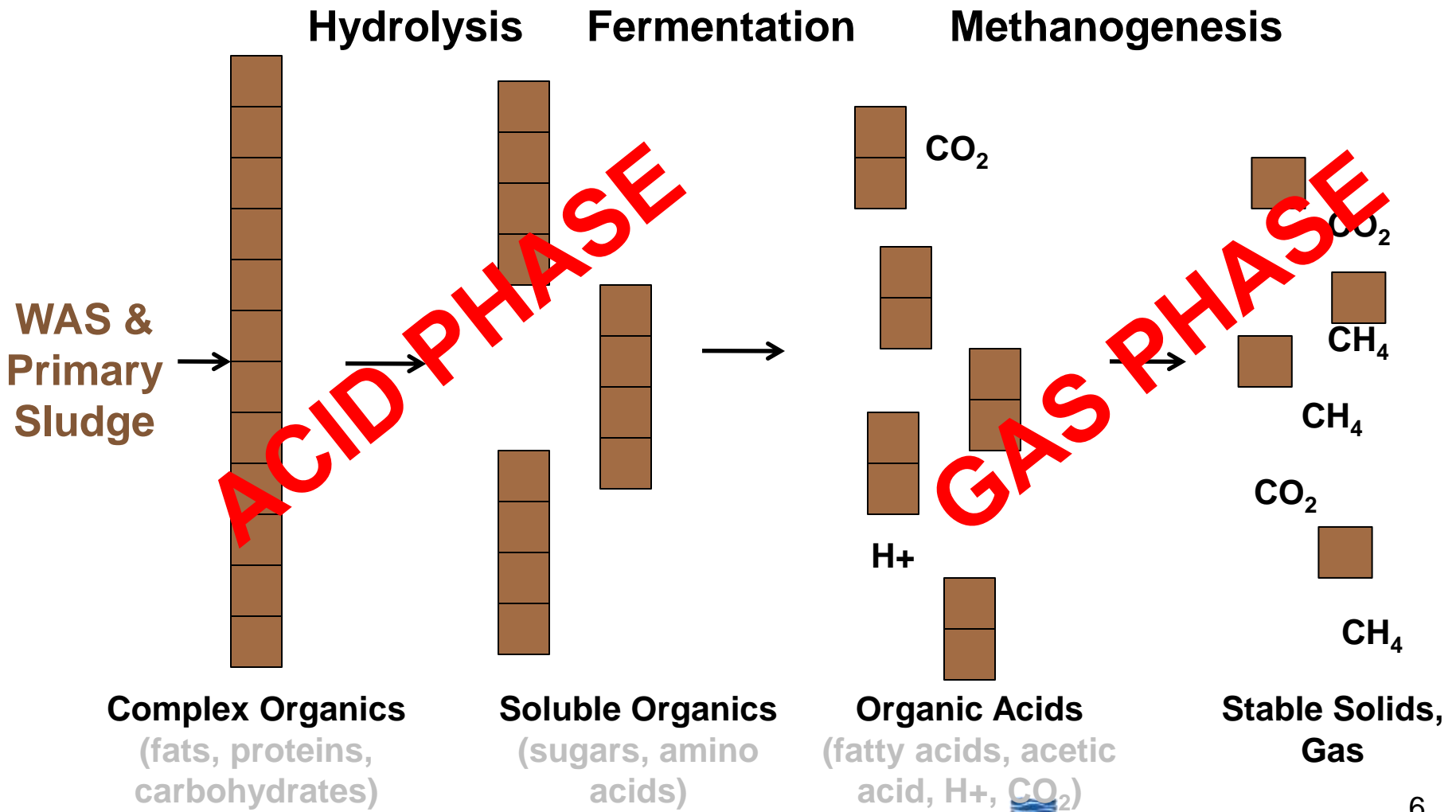

# Background

## Process Comparison Conventional Versus TPAD

### Conventional Mesophilic Digestion

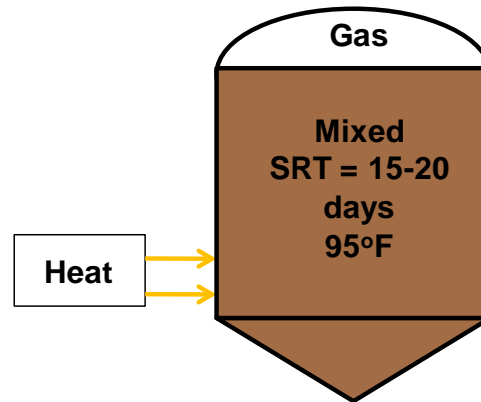

### Temperature Phased Anaerobic Digestion (TPAD)

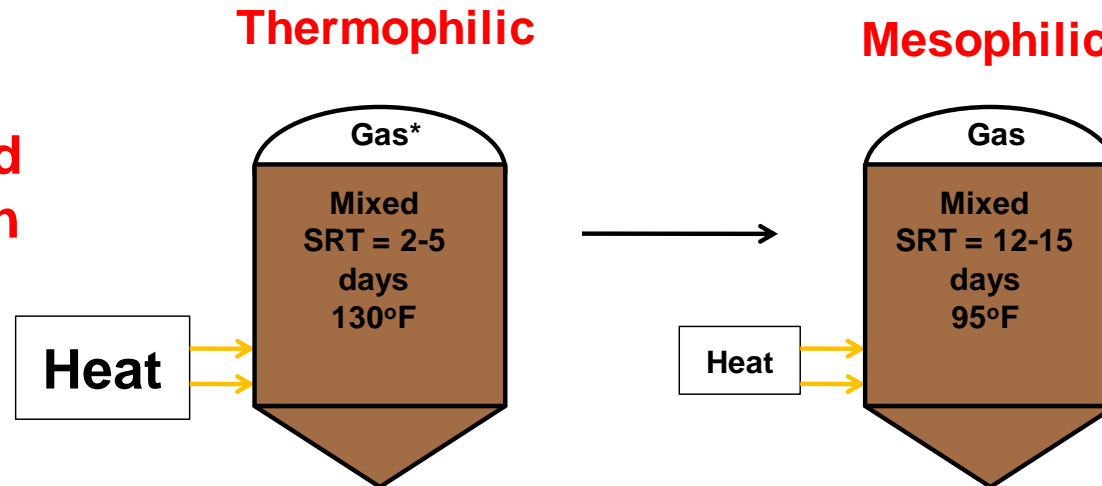

# Digestion Process Background:

## Phased Digestion Advantages/Disadvantages

Advantages	Disadvantages
May be potential for Class A Biosolids	Increased Energy Demand
Higher VS Reduction (less handling, dewatering, disposal, etc.)	More Complex to Operate (attention to loading rates, temperature, pH, balance between two systems)
Increase in Gas Production (about 15%)	Higher H <sub>2</sub> S Concentration in Gas
Reduced Foaming	Potential of Odor
Decreased Sludge Volume (about 13%)	Higher Ammonia concentrations in dewatering filtrate
Increase in Capacity (can accept higher loading rates, n/a for South Bend)	
Dewatering (literature reports both improvements and challenges with dewatering sludge following phased digestion)	

# Background

## Process Alternatives 2M

---

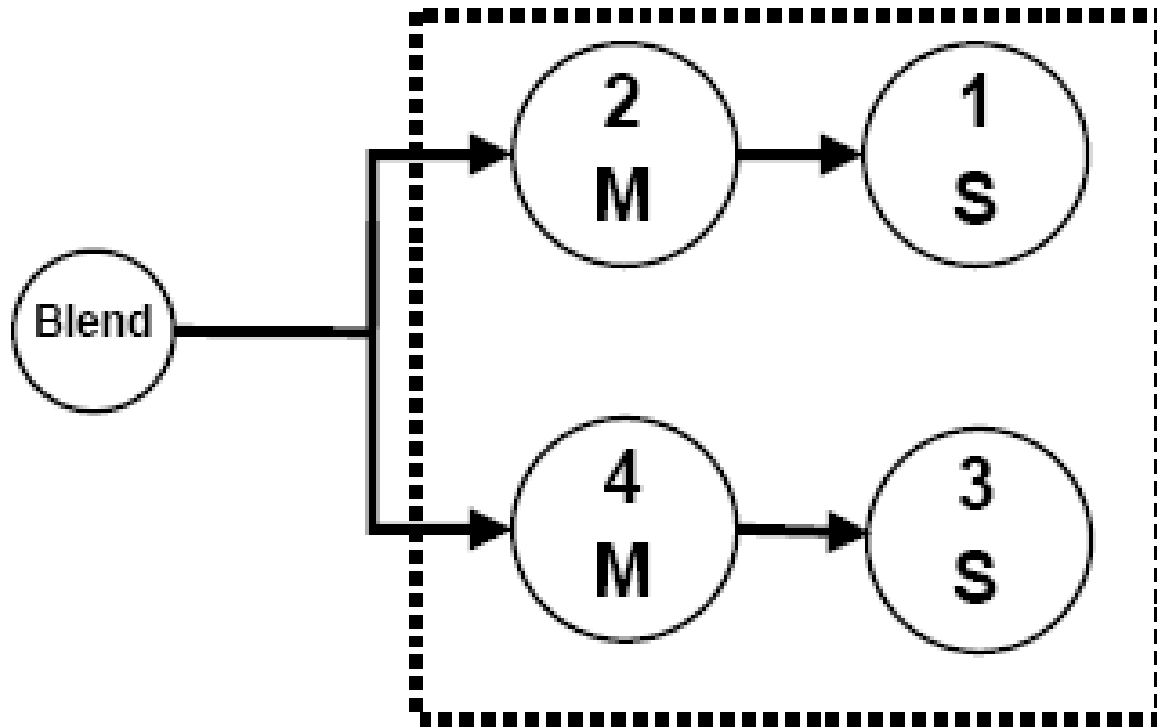

# Background

## Process Alternatives 1T1M

---

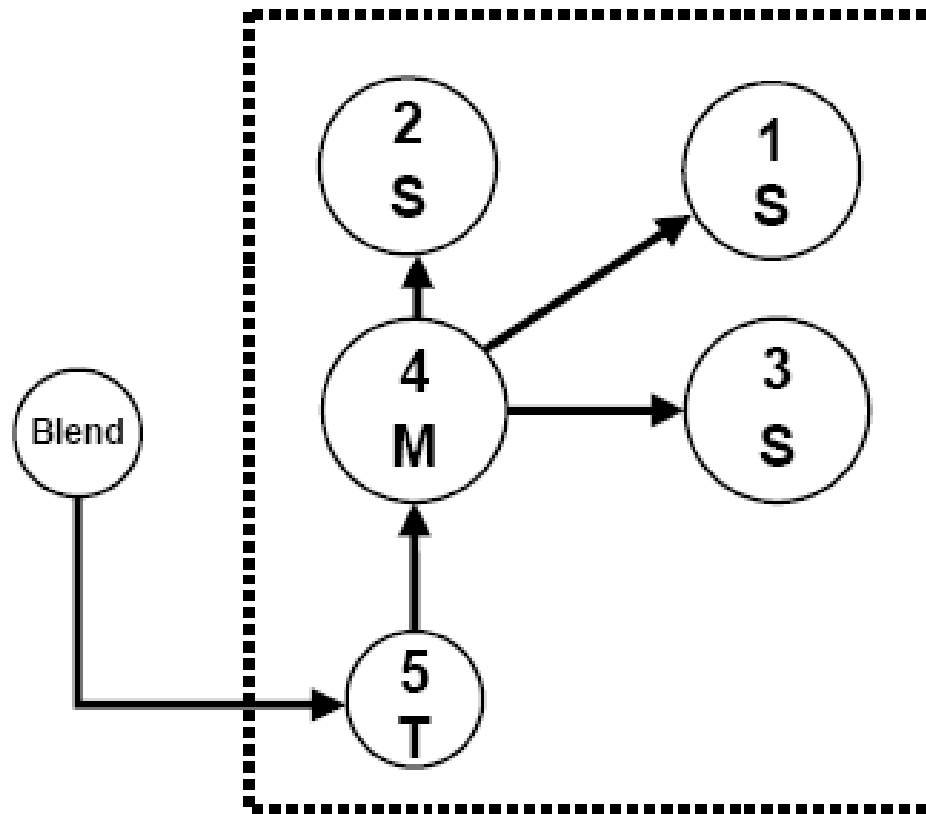

# Background

## Process Alternatives 1T2M

---

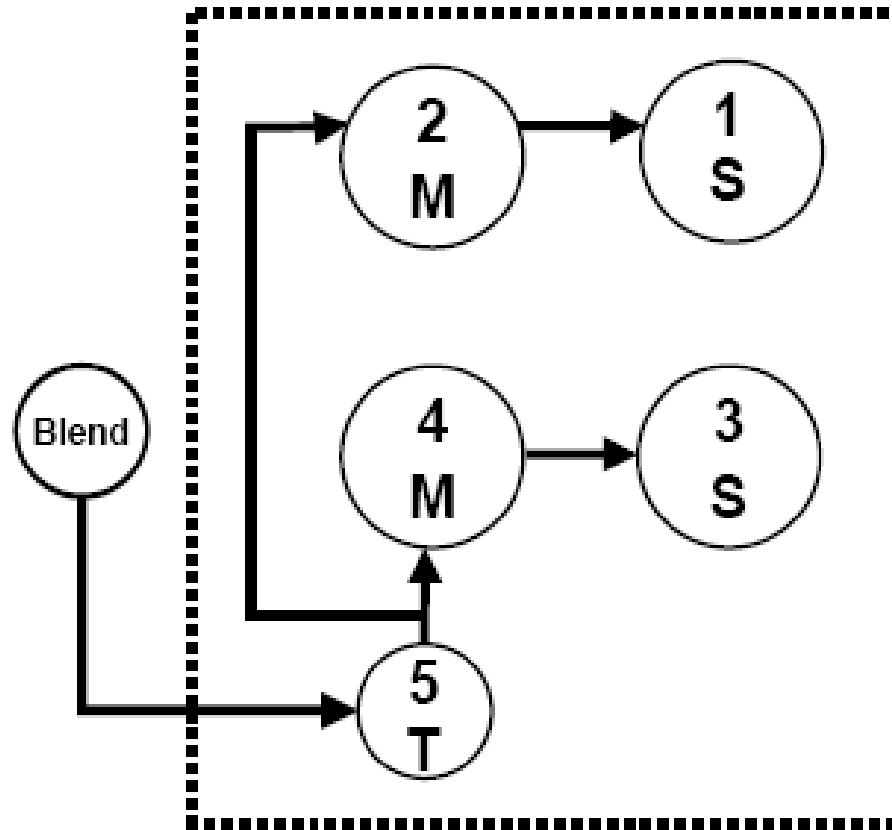

# Background

## Process Alternatives 2T2M

---

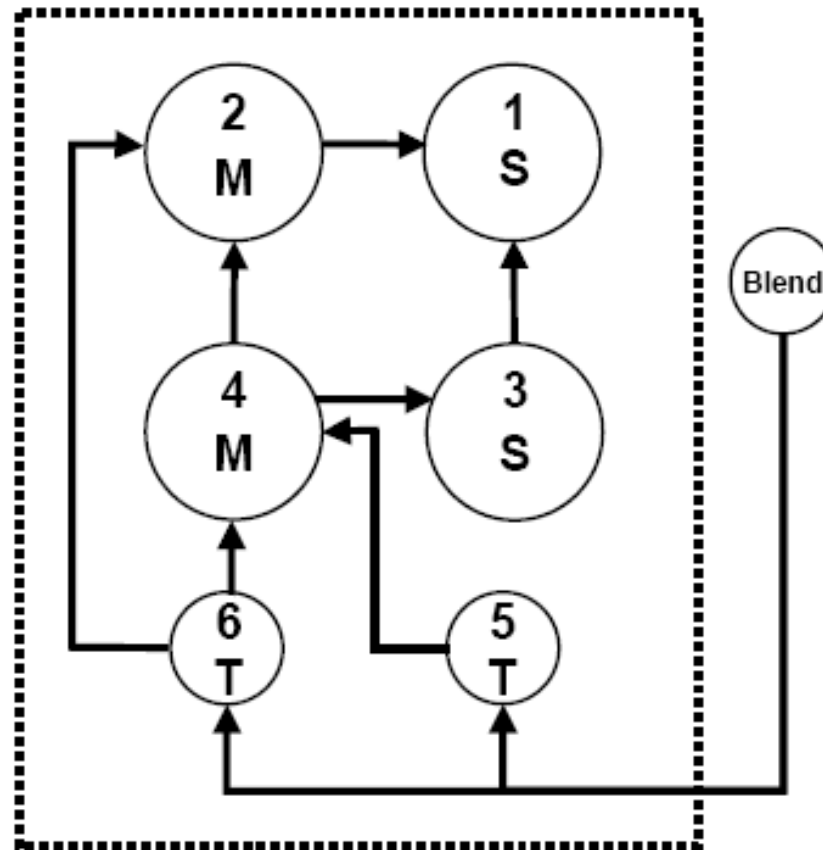

# Optimization

## Volatle Solids Loading Rate

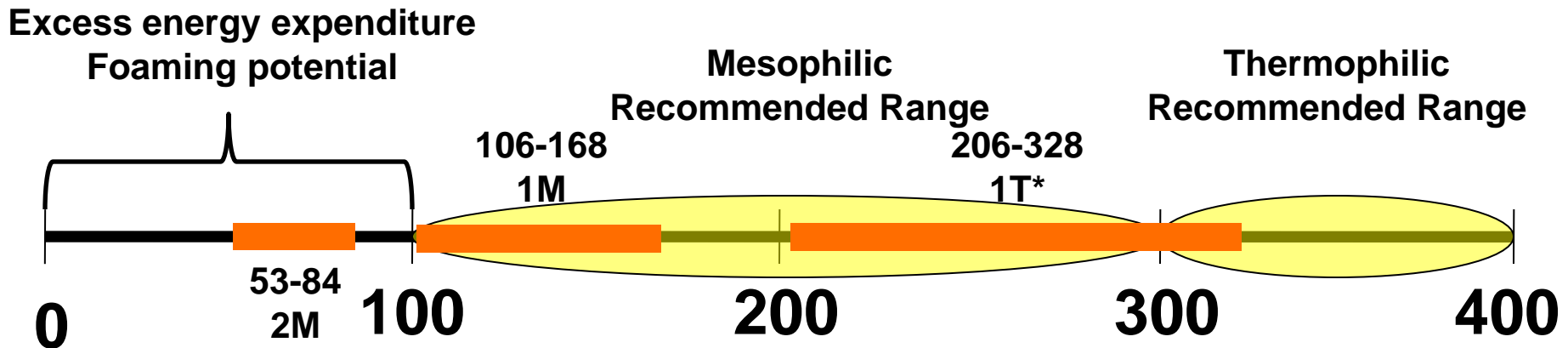

\*Assuming 80'  
thermophilic tank



**1b VS/1,000 cf·d**

**The existing digesters are large and have excess capacity. Cannot use existing tanks for thermophilic digesters**

# Optimization Solids Retention Time

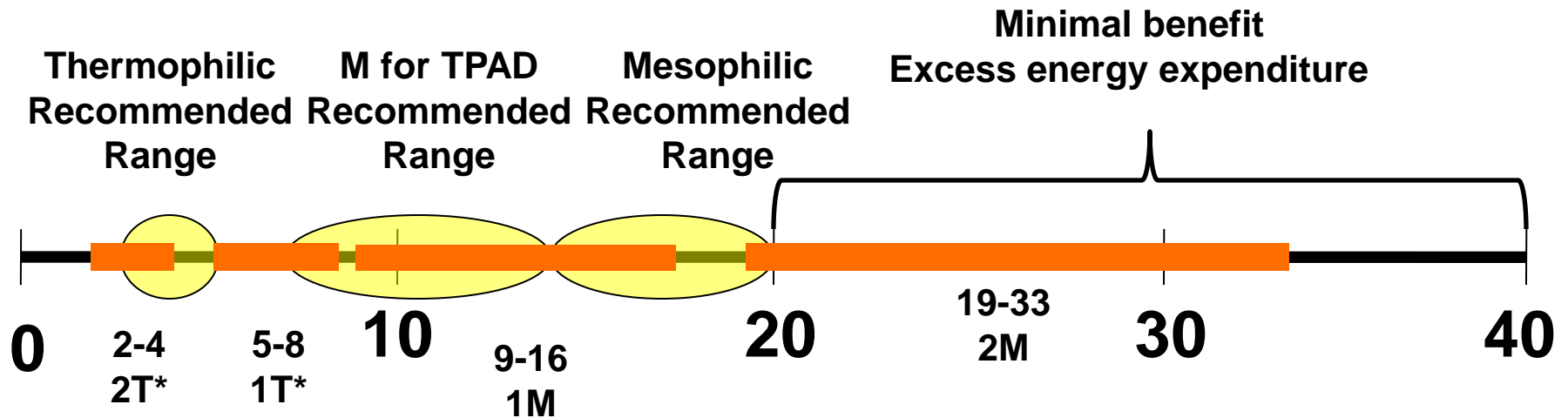

\*Assuming 80' thermophilic tank



The existing digesters are large and have excess capacity. Cannot use existing tanks for thermophilic digesters

# Optimization Net Energy

## Total Energy Required to Heat Digesters

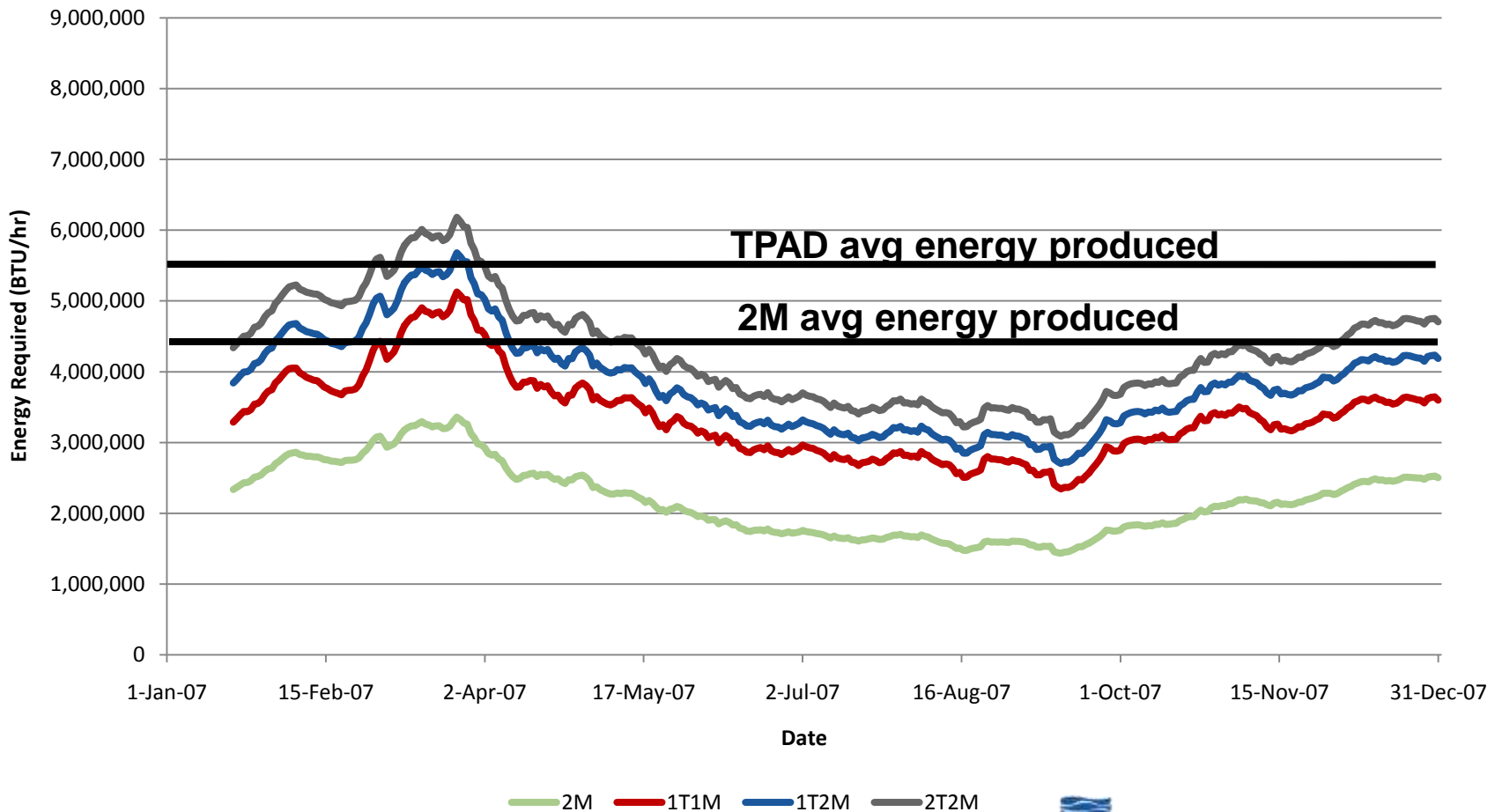

# Optimization Net Energy

Energy Demand Versus Production  
Average Conditions

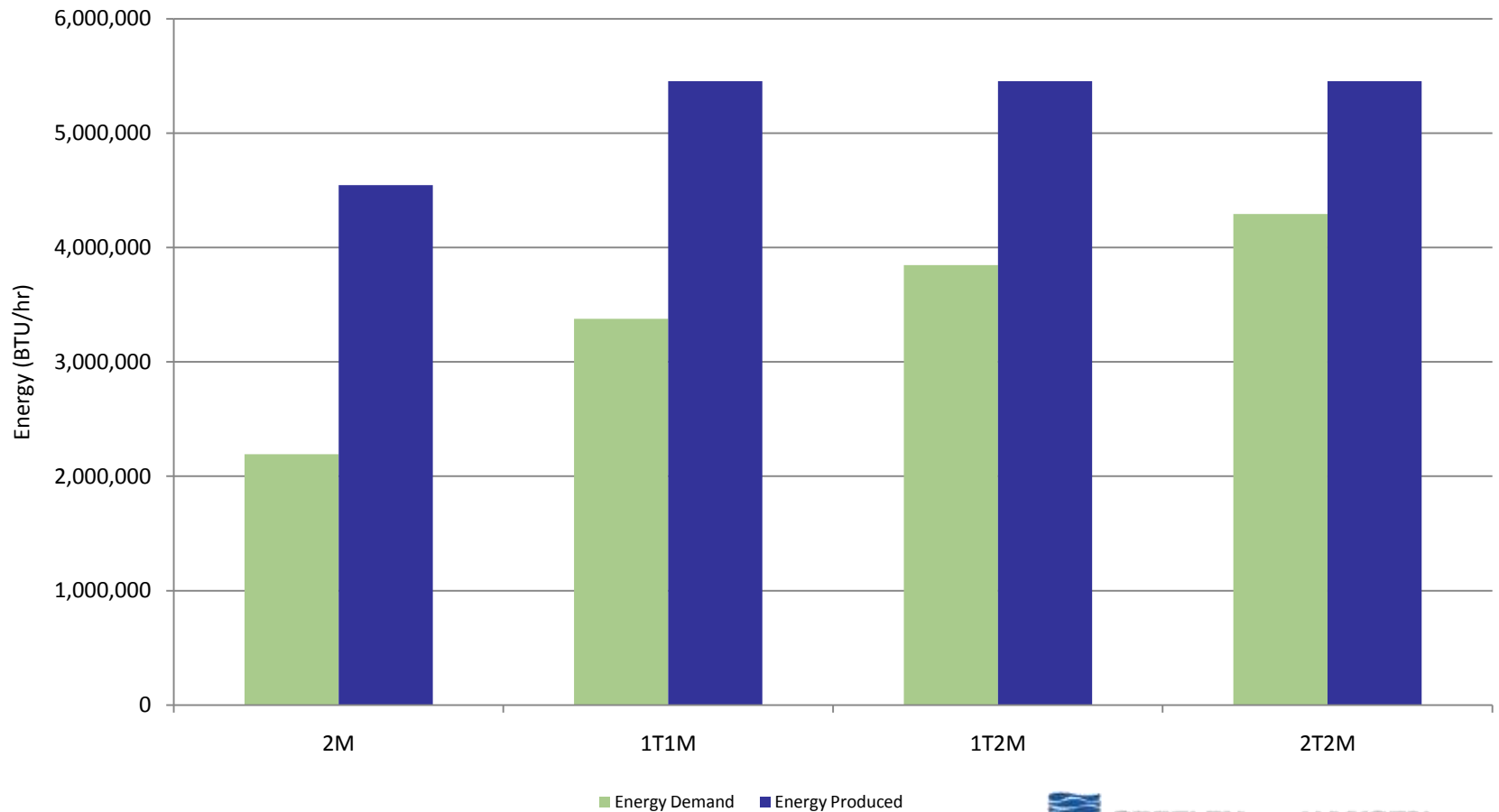

# Conclusion Matrix

Goals	2M	1T1M	1T2M	2T2M
Reliable Operation	Green	Yellow	Yellow	Yellow
Increase Net Energy Production	Green	Yellow	Yellow	Red
Cost Effective	Green	Yellow	Yellow	Red
Class A Sludge	Red	Yellow	Yellow	Yellow

# Questions?

---